

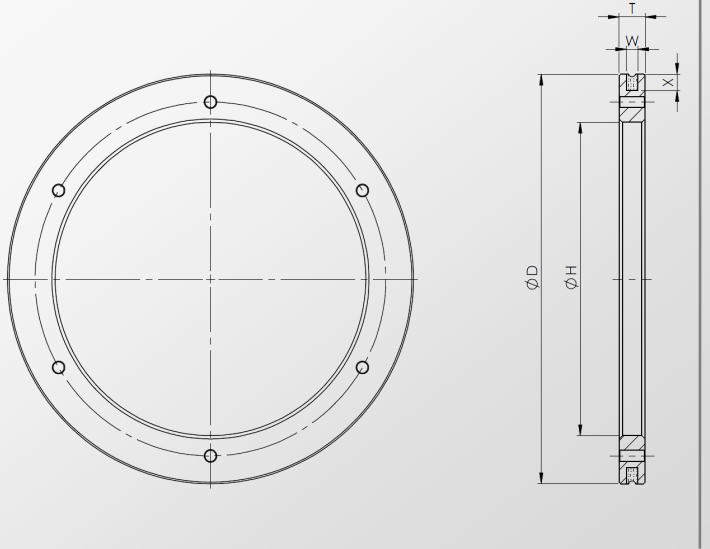

# grinding of GLASS EDGES

# GRINDING WHEELS URDIAMANT



The grinding wheels produced by the **URDIAMANT** company are suitable for grinders of all world manufacturers:

- Bystronic
- Bando
- Glassline
- Bottero
- Bavelloni
- Intermac, ...

As standard, grinding wheels are produced in the following dimensions:

<b>D</b> [mm]	100	150	175	200	250
<b>W</b> [mm]	5 ÷ 10	5 ÷ 10	5 ÷ 10	5 ÷ 10	5 ÷ 10
<b>X</b> [mm]	5 ÷ 10	5 ÷ 10	5 ÷ 10	5 ÷ 10	5 ÷ 10
<b>H</b> [mm]	According to customer's requirements				
<b>T</b> [mm]					

Apart from the standard range, our company can offer a range of non-standard wheels according to customer's requirements.

## DIAMOND

The type, grain size and abrasive concentration differ according to the specific use

GRAIN SIZE - FEPA	GRAIN SIZE - mesh
D181	80/100
D151	100/120
D126	120/140
D107	140/170
D91	170/200
D76	200/230
D64	230/270
D54	270/325
D46	325/400
D39	400/500

## TYPE OF BOND

The company divides bonds into two classes, each class is suitable for a specific use of grinding

TYPE OF BOND	NAME OF BOND
STANDARD	BZ-ST10
	BZ-ST20
	BZ-ST30
HIGH HARDNESS	BZ-XT10
	BZ-XT20
	BZ-XT30

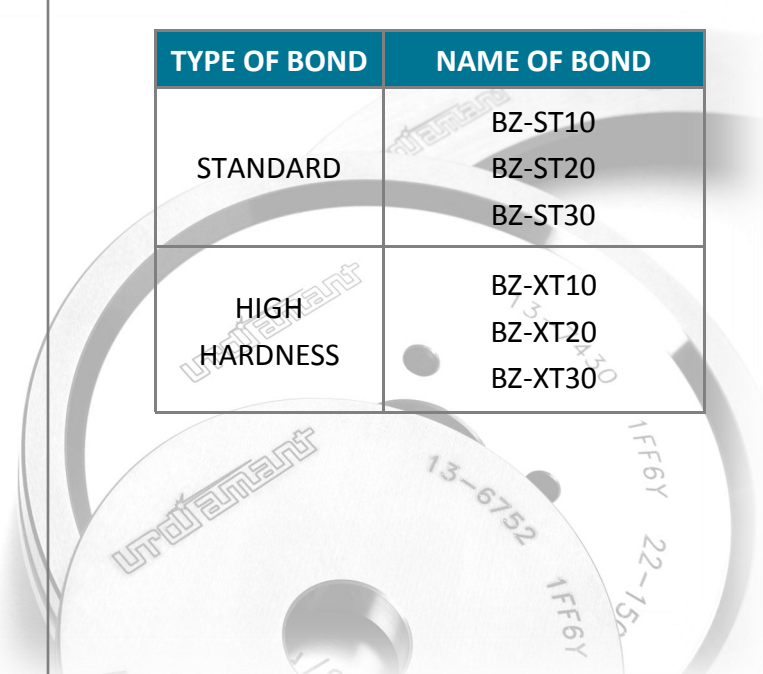

# SHAPING OF THE GRINDING LAYER

The company recommends the use of electric discharge machining (EDM) method for production and re-shaping of wheels. The main advantages of this method include:

- A computer controlled process
- A wheel profile of very narrow tolerances
- Production of profiles which cannot be made by conventional methods
- Prevention of damage to the diamond
- Precise centring of the grinding layer
- It is possible to produce precise profiles according to customer's requirements



## STANDARD WHEEL SHAPES

- Other profile shapes upon customer's request
- Depending on the dimensions of the grinding layer, **URDIAMANT** wheels can be reshaped up to 5 times

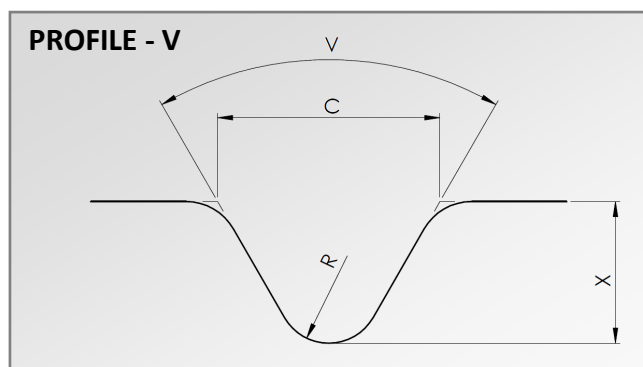
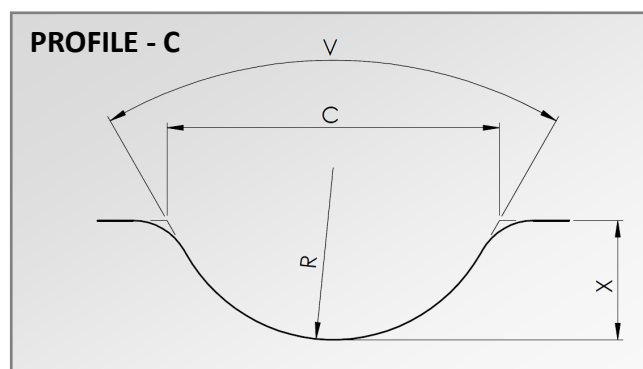
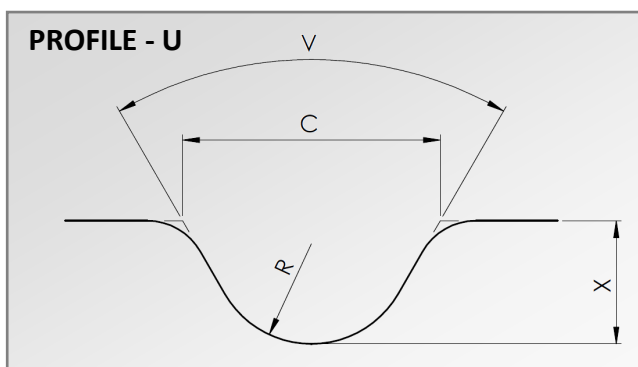



URDIAMANT

## Headquarters

### **Urdiamant, s.r.o.**

Dolnostudénská 715/3, 787 01 Šumperk, Czech Republic

telefon: + 420 / 583 366 111, fax: + 420 / 583 213 026

## Subsidiaries

### **URDIAMANT SLOVAKIA, s.r.o.**

A. Kmeťa 17/10511, 036 01 Martin, Slovakia

telefon: + 421 / 433 240 288-9, fax: + 421 / 432 812 002

### **URDIAMANT Sp. z o.o.**

Katowicka 3, 43-300 Bielsko-Biala, Poland

telefon: +48 338 212 130

Copy protected with Online-PDF-No-Copy.com



[www.urdiamant.eu](http://www.urdiamant.eu)